

# COLORADO MILL EQUIPMENT ECO-BE BUCKET ELEVATOR

Colorado Mill Equipment offers the ECO-BE line of bucket elevators to assist our customers' pellet line needs. The elevators feature high-quality double-row spherical and tapered roller pillow block bearings, drum style slatted boot pulleys, rubber leg belt and heavy gauge construction. These solid, reliable handling systems come in three capacities: 175, 500 or 800 bushels per hour.

## Specifications:

### Head:

- Explosion vent standard
- Crowned drum-style pulleys with SCOF vulcanized lagging or removable slide lagging
- Heavy-duty double tapered pillow block bearings on turned, ground and polished shaft. Dust seals and bearing supports are included.
- Shaft mount torque arm speed reducers with taper lock bushings are standard.

### Trunking:

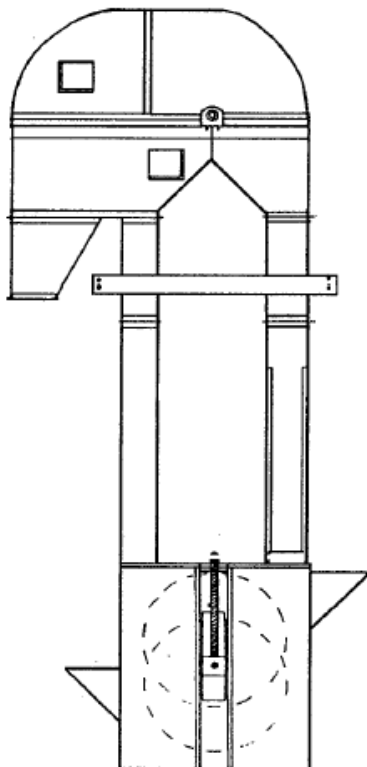

- Heavy Duty jig/robot continuous seam welded trunking
- Angle iron tie braces at 8' intervals
- Reinforced inspection sections with removable covers provide convenient inspection & service of belts/cups

### Boot:

- Heavy duty upside/downside hoppers with dual cleanout slides
- Self cleaning wing style boot pulleys ride on heavy duty shafts

### Options include:

- Ladder
- Platform
- Backstop



## ECO-BE BUCKET ELEVATOR

The ECO-BE can be used to handle the following products:

- Animal Bedding
- Animal Feed
- Biomass
- Chemicals
- Fertilizer
- Hops
- Plastic
- Recycling
- Wood Pellets

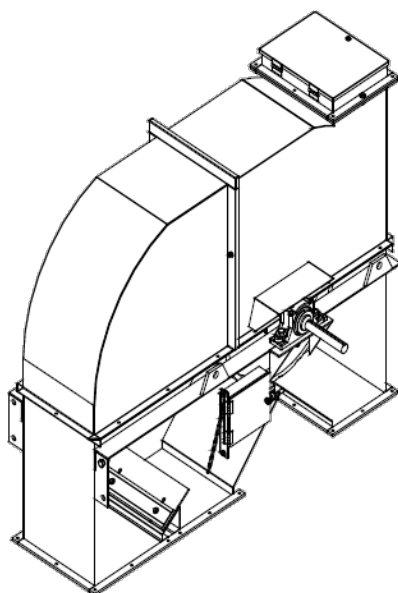

Model/Capacity	Capacity (75% Bucket Fill)			
	BPH	CFPH'	Ton/Hr 60 lb/cf	Ton/Hr 70 lb/cf
<b>BE-175</b>	175	220	6.6	7.7
<b>BE-500</b>	500	630	18.9	22.0
<b>BE-800</b>	800	1000	30.0	35.0

Capacity (BPH)	Cup Size/Spacing		Pulley RPM	Belt FPM	Pulley Dia.	Trunk Dim.
175			78	122		
500	6x4	5	168	264	6	5 ½ x 8 ½
800			202	317		